

# INON

## INON Quick Holder Set S-Z

Thank you for purchasing INON product.

INON "Quick Holder Set S-Z" is a set of "Quick Holder Z" to attach INON strobe etc. on "Quick System", and "Quick Base S" to be attached on YS Mount arm/adaptor.

- Package contents:**
- Strobe Base ① x1
  - M4 x 8 Low Head Cap Screw ② x4
  - Quick Holder Base ③ x1
  - Allen Wrench (WAF:2.5mm) ④ x1
  - Allen Wrench (WAF:5mm) ⑤ x1
  - Quick Base S ⑥ x1
  - M8 Thumbscrew ⑦ x1
  - This user manual x1

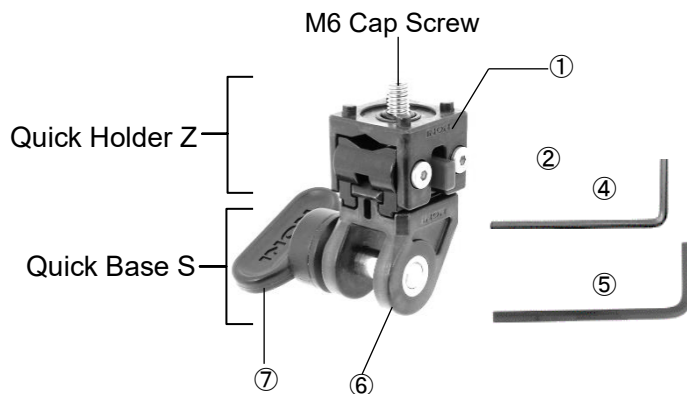

**Compatible Products:**  
(as of July 2019)

**[Compatible strobe]**

- INON "Z-330", "D-200", "S-2000", "Z-240", "D-2000", "D-2000S", "D-2000W/Wn"

**[Compatible Front Mask/Mount Base]**

- INON "SD Front Mask for HERO5/6/7J"
- INON "SD Front Mask STD"
- INON "SD Mount Base UWH1"
- INON "SD Mount Base for TG-Tracker"

**[Compatible YS Mount arm]**

- INON "Shoe Base II", "Direct Base YS RT", "Direct Base YS", "Bar Mount", "Grip Base D4", "Grip Base M1", "D Holder", "D Holder Extension Bar", "YS Adapter MV", "Double YS Adapter MV", "YS Adapter WB MV", "YS Adapter YS Arm MS Body", "YS Arm M Body", "Port Arm for MRS", "Port Arm for UFL-MR130 EFS60"

**Installation:**

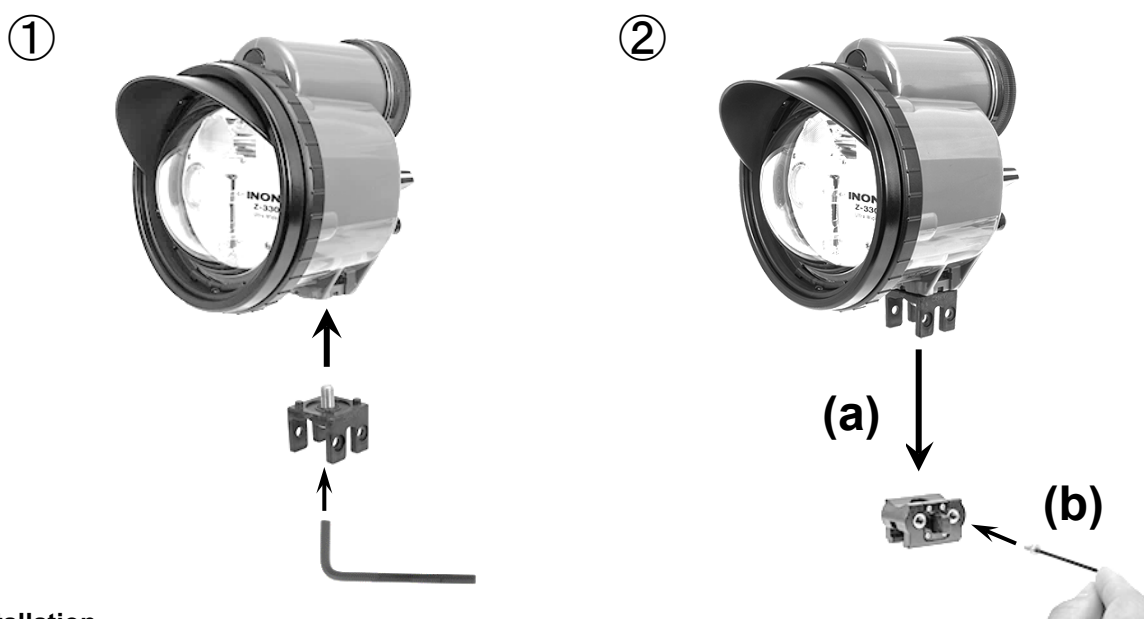

**Quick Holder Installation**

- ① Screw the pre-installed "M6 Cap Screw" of the "Strobe Base" in the screw hole on the bottom of the compatible product (strobe etc.) by using supplied Allen Wrench (WAF: 5mm).
- ② Put the "Quick Holder Base" in the "Strobe Base" so that their screw holes are matched. (a) Grease up screw holes of the "Quick Holder Base" by using INON grease, then fasten the "Quick Holder Base" on the "Strobe Base" with packaged "M4 x8 Low Head Cap Screws". (b)

## Quick Holder System Installation/Removal

- ① With pressing the Lock Button, insert male slide of the "Quick Base" into female slide of the "Quick Holder Z"
- ② Release the Lock Button once the "Quick Holder Z" has come to the lock position as show in center of below images. Except for lock position, female slide of the "Quick Holder Z" and male slide of the "Quick Base" won't be engaged.

**\*Before use, make sure that "Quick Holder Z" and "Quick Base" is securely fastened at lock position.**

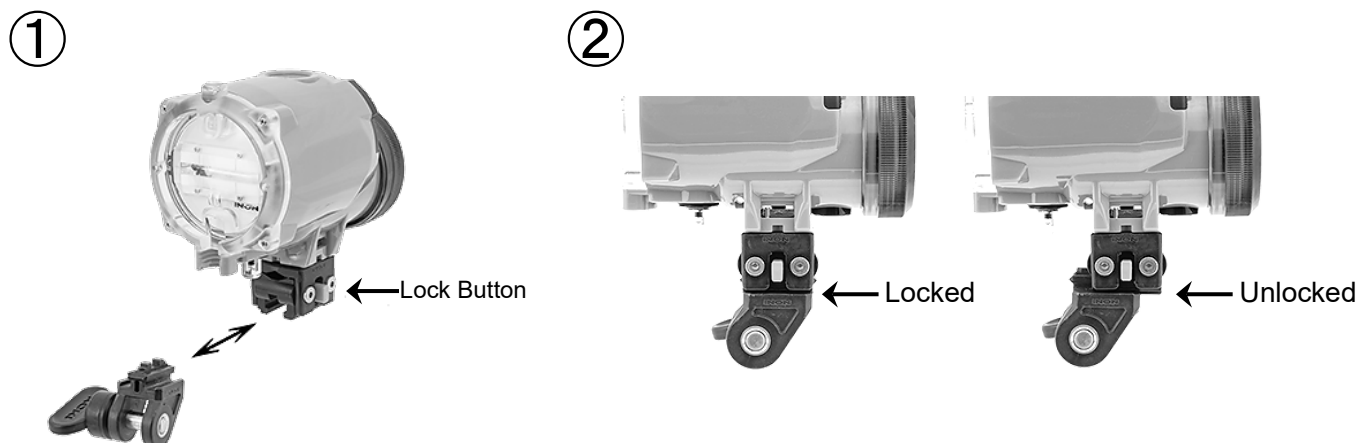

### Maintenance:

- After using, soak in fresh water to dissolve remaining salt or remove dirt and dry it in shaded and well ventilated area. Never apply flame or direct heat to this product or damage may result.
- **DO NOT** clean with organic solvent like alcohol, benzene or thinner and oil and fat containing / chemical material like rust inhibitor, lubricant, polish, detergent (especially alkaline detergent) to avoid damage/deformation/degradation of this product (PC part etc.).
- Remove the combined product from this product when not using more than one week to avoid damage/deformation of the combined product resulting from continuous pressure.
- Periodically grease up screw holes (threaded holes) on the "Quick Holder Z"/"Quick Base S" and threaded part of screws with INON grease to prevent anchoring of screws due to salt build-up or electrical corrosion.
- If the Lock Button doesn't move smoothly over the period of time, apply INON grease.

### Storage:

- Store out of direct sunlight in well-ventilated, dry area. Avoid storing near chemicals, high ozone, large temperature and humidity fluctuations to avoid deformation, damage, rust, mold or corrosion etc.
- Keep the product out of reach of children. They may swallow parts of this product. See a doctor immediately if a child swallow parts.

**Handling Precautions:** • When transporting, be sure to hold "whole of camera system" instead holding this product only or combined product (strobe etc.) only and **DO NOT** apply excessive shock, vibration or excessive load on the combined system to avoid combined product or this product being fell off/damaged /missing.

INON Quick Holder Set S-Z Specifications [*1]	
Model	INON Quick Holder Set S-Z
Size (W x H x D)	26.8 x 53.7 x 34.1mm/1.1 x 2.1 x 1.3 in. [*2]
Weight	66g/2.3 oz (air), approx.35g/1.2 oz (underwater)
Material/finishing	PC/stainless

\*1 Specifications are subject to change without prior notice.

\*2 Excluding Thumbscrew

INON Inc.  
 2-18-9, Dai, Kamakura,  
 Kanagawa 247-0061 JAPAN  
 E-mail [support@inon.co.jp](mailto:support@inon.co.jp)  
 Fax. +81(0)467-48-2178  
 URL <http://www.inon.jp/>

July, 2019