

# INON

## INON Optical D Cable/Cap W54 Set Type L with Clear Photo System Film

Thank you for purchasing INON product

INON Optical D Cable Cap Set Type L connects INON strobe and compatible digital camera housing and employs 「INON Clear Photo System (PAT.P)」 which effectively prevents backscatter, ghost/flare.

Optical D Cable/Cap W54 Set Type L is exclusively for Canon genuine housing 「WP-DC34」.

### Features

- Reliable slave flashing of [Optical D Cable connection] with fiber optics under bright condition like under surface or back lit.
- INON [Clear Photo System] compatible and can effectively prevent drawback of transparent housing like backscatter, ghost or flare to get clear image together with secure connection of [Optical D Cable connection].
- Maximum two 「Optical D Cable Type L」 mountable for dual strobe configuration.

**Package contents :**

Optical D Cable Type L ①	×1
Cap W54 Holder Unit ②	×1
Cap W54 Holder	×1
Optical Guide Cap WL	×1
Optical Guide Mirror M	×1
Cap Fixing Dial	×1
Fiber Optics Fixing Dial	×1
Fiber Optics Fixing Rubber	×1
Cap W54 Holder Fixing Plate ③	×1
M4 Cap Screw (incl. one spare) ④	×3
M4 Washer (incl. one spare) ⑤	×3
Spare Fiber Optics Fixing Rubber ⑥	×1
Allen Wrench (3mm WAF) ⑦	×1
Clear Photo Film ⑧	×3
Protective Film ⑨	×6
Film Sticker ⑩	×3
This user manual	×1

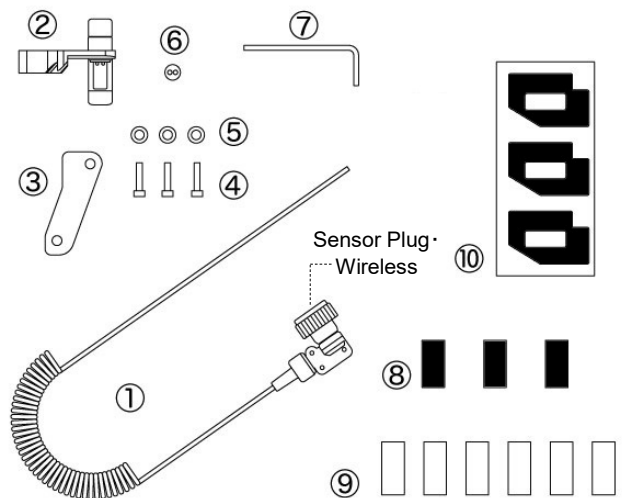

**Compatible housing/:** (as of May 2018)

- Canon WP-DC34

**Compatible strobe :** (as of May 2018)

- **Wireless compatible strobes (Optical D Cable Type L is attached as it is)**  
INON Z-330, S-2000, Z-240 [Type 4], D-2000 [Type 4]

- **Wireless non-compatible strobes (Sensor Plug has to be replaced with optional "Sensor Plug - Non-Wireless" (※))**  
INON Z-240 [Type 3/ Type 2/ Type 1], D-2000 [Type 3/ Type 2/ Type 1], D-2000W, D-2000Wn, D-2000S, D-180, D-180S, Z-220F, Z-220S, Z-220
- INON TTL Sensor Z + INON Z-22
- INON TTL Sensor SB + compatible TTL auto strobe
- INON TTL Sensor YS + compatible TTL auto strobe
- INON Focus Light Controller + INON Z-220F/Z-220S/Z-220/Z-22



***[Sensor Plug - Non-Wireless]***  
***[Optional]***

***(※) Refer to an instruction manual [L-Connector Modification Instruction] which comes with the optional [Sensor Plug - Non-Wireless] for detail of replacement***

**Connection method:** There are two patterns to connect your INON strobe and camera system with this product. Though it is depending on shooting condition or intended use which pattern you use, normally we would recommend connection method (A).

- (A) **Clear Photo connection** : Conventional connection method to use Clear Photo System (※) 【1<sup>st</sup> choice】
- (B) **Conventional connection** : Often shoot by only camera (use built-in flash) and hard to remove Clear Photo Film each time. (※※) 【2<sup>nd</sup> choice】

※ : It is necessary to check condition of Clear Photo Film/Protective Film before every diving, and to replace them with new one before their deterioration. Clear Photo Film/Protective Film is consumable and deteriorated film may damage camera's built-in flash. Refer to "Checking Clear Photo Film / Protective Film" for detail.

※※ : Only when using built-in flash for macro shot or prefer not using Clear Photo Film. There could be degradation of exposure control or problem on an image depending on optional parts when not using Clear Photo System. Refer to boxed column in the last page for detail.

**How to attach** : **Prepare and attach Film Unit on camera** [Connection method (A)]

Apply a Clear Photo Film (black) and a Protective Film (clear) in order on adhesive side of a Film Sticker. Attach the Film Unit (Clear Photo Film / Protective Film / Film Sticker) on a camera so that it covers built-in flash surface and the Protective Film touches built-in flash surface.

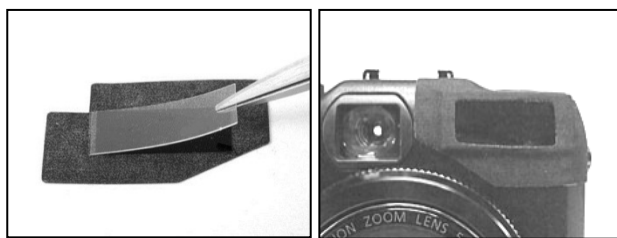

**Attach Cap W54 Holder Unit on housing**

Put the "Cap W54 Holder Unit" on the left strap eye-let (circled by dashed line in below image ①) so that the eye-let seats in the groove of the Holder Unit ②. Then place the "Cap W53/W54 Holder Fixing Plate" underneath the eye-let to sandwich the eye-let with these two parts ③. Then adjust position of the "Cap W54 Holder Unit" and "Cap W53/W54 Holder Fixing Plate" to make their sides in plane and partially fasten them by supplied two sets of M4 cap screw and M4 washer. Completely tighten M4 cap screws alternately and evenly by supplied Allen Wrench ④(※).

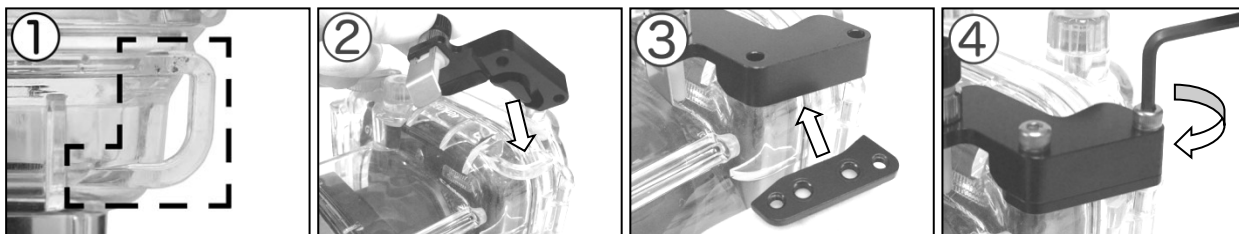

※: Do not tighten too much to avoid accidental damage on the strap eye-let. Make sure there is no debris or foreign substances on the eye-let before installing this product to ensure proper and secure installation to avoid accidental separation of this product and damage of the combined housing.

**Before installation and after removal of this product, check the condition of the strap eye-let and adjacent part to make sure those parts have no crack/deformation. If you observe any irregularity, do not use the housing anymore to avoid accidental flooding.**

**Attach Optical D Cable Type L**

Unscrew Fiber Optics Fixing Dial and inlet an Optical D Cable Type L into a hole of Fiber Optics Fixing Rubber all the way. Then tighten the Fiber Optics Fixing Dial to fix the cable. Maximum two Optical D Cable Type L can be set. Attach the other side of the cable to strobe's slave sensor.



- Handling precaution:**
- Optical D Cable Type L has ultra durability (minimum bend radius 2mm) but inner portion could be damaged when bending less than radius of 2mm or excessive shock. And if the cable being bended for long time, it will not back to original shape. Replace with optional 「Replacement Optical D Cable Type L/Optical Cable M Type L」 in case of poor signal transmission.
  - When carrying your camera system, DO NOT hold the Optical D Cable Type L with being connected to a housing or a strobe to prevent the fiber optics coming off from the L- Connector or accidental damage on strobe/L-Connector/Optical Cable etc.
  - Film Sticker, Clear Photo Film and Protective Film is designed for multiple usages. When you remove the Film Unit (Film Sticker/Clear Photo Film/Protective Film), attach it back on sticker mount. In case the Film Sticker lose adhesion or Clear Photo Film gets damaged, optional 「Cap 3/W3/W22/W27/W33/W34/W36/W53/W54 Clear Photo Film Set」 is available.
  - After installing this product, do not apply excessive shock, vibration or stress and also do not hold this product only to carry whole camera system to avoid accidental damage on the combined housing.

- Checking Clear Photo Film / Protective Film :**
- Clear Photo Film is a filter which transmits only infrared ray and does not store heat in normal circumstances. However Clear Photo Film is consumable and its transmitting faculty could be degraded during multiple usages.  
Especially when using Clear Photo Film with a camera equipping strong built-in flash (flash output per time is comparatively large) or making built-in flash at its full power every time (this could not happen in normal situation when using INON strobe equipping “Advanced Cancel Circuit”), heat of flash could degrade / burn / melt Clear Photo Film leading to insufficient transmitting.  
If the degraded Clear Photo Film keeps to be used, built-in flash can store heat and may have heat deformation on its prism part (※).
  - To avoid the damage on built-in flash, please make sure to check Clear Photo Film and replace as necessary when using INON Clear Photo Film [Connection method (A)].

- **Please check condition of [Clear Photo Film/Protective Film] after usage and replace with new one before you observe any sign of burn/melt.**
- **It is recommended to avoid shooting condition where built-in flash emits full amount to prevent [Clear Photo Film/Protective Film] from degradation.**

- [Connection method(B)] which does not use Clear Photo Film and not necessary to exercise periodical check/replacement of Clear Photo Film/Protective Film.  
However exposure control could be less accurate or problem in an image could be possibly observed. Refer to boxed column on the last page for detail.
- ※ As of December 2010, degradation/burn/melt of Clear Photo Film/Protective Film is only observed when using with C-5060WZ/C-7070WZ. However it may be possible to have that kind of degradation with other camera model depending on usage condition.

- Maintenance :**
- Soak the Optical D cable/Cap Set in fresh water (below 30°C / 86°F) for several hours after use to dissolve any salt build up. Blow off water drop by air gun/blower and dry the Optical D cable/Cap Set in shaded and well ventilated area. It may take several days to completely dry.
  - Especially take care to clean the both edge of the Optical D Cable with the cable removed from Cap W54 Holder Unit to dissolve any salt build up. Scratch or cloud with salt build up on the edge may lead poor signal transmission.
  - Be careful not to lose parts of Cap W54 Holder Unit and not to separate a rubber sheet pasted on the under surface.
  - In the event of poor signal transmission resulting from scratch/cloud or necessity to shorten the cable, it is possible to cut the cable to refresh the damaged edge or to get desired length. Refer to our web site below to cut strobe connector side.

“L Connector Modification Instruction”  
<http://www.inon.jp/pdf-dl/userdata/ModifyCableConnector-en.pdf>

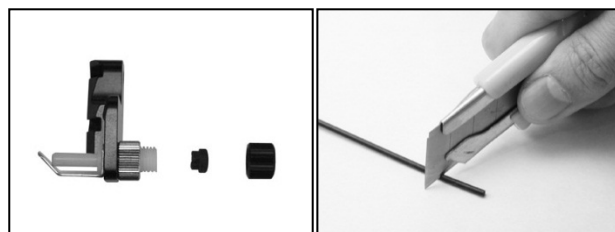

When you cut the Optical D Cable Type L, use sharp blade like a razor or a utility knife and make sure to cut the edge flatly. If you observe roughness on the cable section, cut it again to prevent poor signal transmission.



- Before installing this product :**
- Please note that housing manufacture has no concern with the installation of this product on the housing. Do not inquire housing manufacture about the installation. Also please note that you have to take full responsibility for the installation.
  - Warranty of housing may be void by installing this product even though warranty has not been expired. Refer to housing user manual/warranty statement for detail.

- INON Inc. can not take any responsibility for any trouble/damage (damage to housing/housing accessories/camera) resulting from the installation.
- Should you have trouble like flooding caused by the installation, INON Inc. can not take any responsibility for incidental damage (relevant expense to take a shot etc.)
- Please perform the installation only if you can accept above conditions. Otherwise do not make the installation.

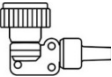
#### Optional Parts

- Optical D Cable Type L  
① in the product illustration on the first page. Necessary when using 2nd strobe to connect with Cap W54 Holder Unit.
- Replacement Optical D Cable Type L/Optical Cable M Type L  
① in the product illustration *without connector*
- Cap 3/W3/W22/W27/W29/W33/W34/W36/W53/W54 Clear Photo Film Set  
Film set consists of ⑧, ⑨ and ⑩ in the product illustration.
- Cap W54 Holder Unit (with spare parts)  
②, ③, ④, ⑤, ⑥ and ⑦ in the product illustration.
- L-Connector Kit (strobe) · Wireless  
Replacement strobe connector unit without a cable. Same strobe connector as originally installed on this product. 
- Sensor Plug · Wireless  
Replacement sensor plug unit originally installed on this product. 
- Sensor Plug · Non-Wireless  
Replacement Sensor Plug unit to be replaced with originally installed Sensor Plug to use for Non-Wireless strobes described on the first page of this manual. 

#### ※ When you use External Strobe especially using External Strobe under Connection method(D)(without Shade Panel/Clear Photo System) · · ·

In Connection method(D) with an external strobe(slave with built-in flash) or under dual strobe configuration, there might be **possibility to get overexposed image** depending on shooting condition.

This is because minimum total flash output (including built-in flash) beyond necessary light amount for particular shooting condition. **This phenomenon is especially pronounced when using a particular camera (minimum flash output is relatively large) at minimum focusing distance with external strobe without using shade plate or Clear Photo System.** (You can check minimum flash output of your camera by taking shoot at minimum focus distance with fill-in flash) Following countermeasure would be recommended for correct exposure;

- Use under Connection method(A),(B) or (C).
- Stop down camera's aperture (= use smaller aperture)
- Move away a strobe from a subject
- Attach a diffuser on an external strobe [See user manual of strobe]

Also note that this connection method does not completely shade built-in flash light so **back scatter could be increasingly observed.**

#### ※ When using built-in flash with attachment lens without Clear Photo System · ·

When using built-in flash with attachment lens being mounted and Clear Photo System is not used, **there may be possibility to have ghost/flare in an image** depending on shooting condition/camera/housing/mount base.

This is because built-in flash light gets into the attachment lens from its mounting part. **In the case, we would recommend to use an external strobe with Clear Photo System.** If you have to use built-in flash only by necessity, ghost/flare could be reduced by preventing built-in flash light from being get into attachment lens from its mounting part.

INON Inc.

2-18-9, Dai, Kamakura,  
Kanagawa 247-0061 JAPAN

E-mail [support@inon.co.jp](mailto:support@inon.co.jp)

Fax. +81(0)467-48-2178

URL <http://www.inon.jp/>

May 2018