

INON

Safety Precautions

- Before using your flashlight, please ensure that you have read and understood the safety precautions described below and separate 「user manual」 / 「Measures to Prevent Accidental Flooding」. Please keep these documents handy for easy reference.
- The safety precautions are intended to instruct you in the safe and correct operation of the strobe to prevent injuries or damage to yourself, other persons and equipment.
- The symbols and their significance are described below.



DANGER

Failure to observe the precautions indicated by this symbol may lead to high possibility of serious injury or death.



WARNING

Failure to observe the precautions indicated by this symbol may lead to possibility of serious injury or death.



CAUTION

Failure to observe the precautions indicated by this symbol may have the possibility of resulting in possibility of injury or property damage..



WARNING

Do not turn on the flashlight in front of person's eye (particularly an infant).

The flashlight may cause irreparable injury to the eyes or cause temporary visual impairment.

This product is not usable on land except function check for short period of time (not exceeding total operation time 5 minutes). Always use heat-safe gloves etc. when you conduct this function check on land to prevent personal injury like burn/low temperature burn.

Do not use the flashlight in a place where it may be exposed to flammable or explosive gas.

Otherwise fire ignition or explosion may result.

Turn OFF the flashlight when not in use.

Remove batteries immediately after exhaustion.

Batteries could produce flammable gas causing the flashlight to explode. Storing the flashlight with batteries for extended periods of time could cause batteries to leak, overheat or explode which may result in fire, injury or damage to other property.



WARNING

When turn OFF the flashlight, turn the switch completely until it stops. Remove batteries when not using the flashlight for extended periods of time.

Unexpected activation of the flashlight by vibration etc. could cause fire or injury.

Storing the flashlight with batteries for extended periods of time may cause batteries to leak, overheat or explode which may result in fire, injury or damage to other property.

Never attempt to modify the flashlight or disassemble the light head to avoid malfunction, damage or flooding, which could lead to injury.

Prevent water from entering the flashlight to avoid malfunction, damage or flooding, which could lead to injury.

Always check O-rings, batteries and flashlight operation before using to avoid flooding, malfunction and unexpected deactivation of the product due to battery exhaustion, which could lead to an accident.

Stop operating and turn off the flashlight immediately if any water is observed inside flashlight or flashlight operates improperly.

Flammable gas may build up and cause explosion of the product, which may result in serious injury. Remove batteries being careful to avoid electrical shocks or burns. Contact your local dealer for repair.

Do not use flammable solvent containing alcohol, benzene or thinners, oil and fat containing/chemical material like organic solvent, rust inhibitor, lubricant, polish, or alkaline detergent to clean the flashlight.

The use of these substances may lead to fire, explosion or damage to the flashlight.

Keep the flashlight out of reach of children.

Their inability to read and understand warnings may lead to serious injury. They may swallow parts of the strobe or batteries. See a doctor immediately if a child swallow parts or batteries.

The high-voltage circuitry in the strobe may lead to electric shock and /or injury regardless of whether the strobe is equipped with batteries or not. Stop using the strobe immediately and take out the batteries.

Contact your local INON Authorized Dealer for repair.



CAUTION

Do not apply strong vibration or shock to the flashlight by dropping or hitting it against something.

Damage to the flashlight could cause malfunction or flooding possibly leading to injury or fire. Strong vibration/shock could deform batteries or damage battery case causing battery to leak or to generate heat resulting in fire or injury.

Do not “jump” into the water with the flashlight or other photographic equipment to avoid injury which may be caused by malfunction, flooding or unexpected movement of equipments.

Do not leave/store the flashlight in a place subject to strong sunlight or high temperatures, such as a beach, the deck of a boat, dashboard or trunk/boot of a vehicle.

Otherwise damage to the flashlight may result in injury, fire or malfunction.

Partially unscrew the Light Head or remove it for flying or traveling to other areas with lower air pressure than sea level (traveling across mountains for example) to avoid damage to waterproof integrity which may result in flooding or injury.



DANGER

Do not use batteries other than batteries specified in user manual.

[Compatible batteries]

- Panasonic AA “eneloop pro” rechargeable battery (BK-3MCC) [recommended] , Panasonic AA “eneloop pro” rechargeable battery (BK-3HCC / BK-3HCD) [recommended] , and (“eneloop” type) “new generation” NiMH battery with same performance
- “Conventional” NiMH battery (1.2V) other than above [good quality]
- AA Alkaline (1.2V) [good quality]
- AA Lithium (1.5V) [good quality]

Do not use any battery which you observe irregularity including leakage, deformation, discoloration or damage on battery jacket etc.

Do not throw a battery in a fire or heat it. Never attempt to disassemble or short-circuit a battery.

Do not immerse battery in water or allow it to get wet.

Do not mix old and new batteries, recharged and discharged batteries or batteries of different capacities, types, brand or manufacturer.

Do not attempt to recharge non-rechargeable batteries.

Be sure to recharge rechargeable batteries with specified battery charger. Follow battery and battery charger instruction manual.

Do not load batteries with the +/- battery terminal reversed

Follow any other instructions indicated in the battery/battery charger user manual.

Dispose batteries in accordance with all applicable federal, state and local regulations.

If the battery should leak and the inner liquid contacts skin or eyes, immediately wash with a lot of fresh water and seek medical advice.

As of December, 2020

INON

INON LE600h-W

Thank you for purchasing INON product.

The INON LE600h-W is a watertight LED light equipped with high-intensity power LED producing powerful 600 lumen intensity and 75° coverage at color temperature 6500K in its compact body.

Before using, please read through this user manual and separate papers “Safety precautions”/“Measures to Prevent Accidental Flooding” to ensure proper operation of the product. This product is not usable on land except functional check not exceeding 5 minutes operation time in total. Refer to “Handling precaution” section for detail.

Features

- Usable for various purposes even as lighting source for underwater photography/videography thanks to wide 75° coverage and natural 6500K color temperature in addition to a diving light carrying 120m depth rating by its durable corrosion-resistant aluminum alloy and double O-ring construction for moving parts.
- Color temperature is approx. 6500K making it easier to reproduce natural color when mixing with ambient light or strobe light comparing to warmer color temperature torch.
- Operated by easily obtainable 3 x AA batteries. Compatible batteries including “eneloop”/“eneloop pro” etc. support approximately 80 minutes continuous operation* at minimal running cost.
*Average time to get half brightness comparing to initial performance when using “eneloop pro” batteries [Model code: BK-3HCD].
- Packaged **Red Filter LE** is for shy underwater creatures not stimulating them.
- Wide varieties of optional accessories are available including “Light Holder” products to attach this product on your camera/video system.
- Light Head is interchangeable with other compatible model to provide flexible usages.

Package contents :	• LE600h-W ①	x1
	• LE600h-W Light Head	x1
	• 3xAA Battery Box III Unit	x1
	{ 3xAA Battery Box III }	
	{ Switch }	
	• Hand Strap ② (preinstalled on ①)x1	
	• INON Grease ③	x1
	• Red Filter LE ④	x1
	• This user manual	x1
	• Safety Precautions	x1
	• Measures to Prevent Accidental Flooding	x1
	• User manual of filters	x1

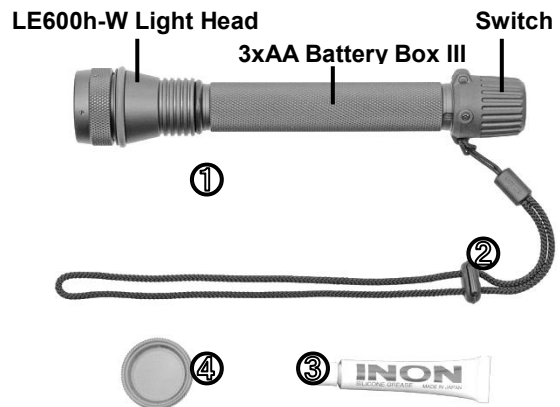

Preparation : **Prepare compatible batteries**

Following 4 types are compatible with this product (*1). Prepare 『three』 batteries (same type/model) from same battery manufacture.

- 1) **Panasonic AA “eneloop” rechargeable battery (BK-3MCC)[recommended], Panasonic AA “eneloop pro” rechargeable battery (BK-3HCC / BK-3HCD)[recommended], and equivalent (“eneloop” type) “new generation” NiMH battery (*2)**
- 2) **AA ”conventional” NiMH rechargeable battery other than above (1.2V) [good quality] (*3)(*4)**
- 3) **AA Alkaline battery (1.5V) [good quality] (*4)**
- 4) **AA Lithium battery (1.5V) [good quality] (*4)**

*1 Other batteries are **not** usable such as AA Manganese battery or AA Oxyride battery etc. Make sure to follow precautions of handling batteries described in separate 『Safety Precautions』.

*2 Including “new generation” NiMH batteries (“eneloop” type) carrying less self-discharging and heat generating characteristic comparing to “conventional” or “high-capacity” NiMH battery.

*3 Some “conventional” or “high-capacity” NiMH rechargeable batteries have significant self-discharge and heat-generating characteristic resulting difficulty to keep their performance during usage. We recommend using recommended batteries.

*4 Run time very much depends on battery characteristic, quality. Make sure to use quality battery supporting continuous discharge of large current not to have battery leakage as well.

(continued)

Separate LE600h-W Light Head and 3xAA Battery Box III Unit

Holding the "3xAA Battery Box Unit III" firmly, **turn OFF the LE600h-W** by slowly rotating the "switch part" counterclockwise until it has been stopped. **Then slowly turn the "LE600h-W Light Head" counterclockwise** to remove the unit from the 3xAA Battery Box III unit. To keep waterproof property, make sure slowly turn the switch/LE600h-W Light Head to prevent O-ring from being damaged/twisted.

Install Batteries after Checking O-ring etc.

Check conditions of O-rings etc. and conduct leak test if necessary to ensure waterproof property in accordance with separate paper "**Measures to Prevent Accidental Flooding**".

Next, conduct maintenance of battery terminals and terminals/contacts on the LE600h-W in reference to 「Terminals/Contacts Maintenance」 section of this user manual. Then install batteries in the "3xAA Battery Box III" with correct orientation as shown in image right and indicated on a sticker inside of the "3xAA Battery Box III" [positive(+) terminal towards to the Light Head and negative (-) terminal towards to the Switch].

Also make sure to follow any handling precautions on battery mentioned in separate "**Safety Precautions**".

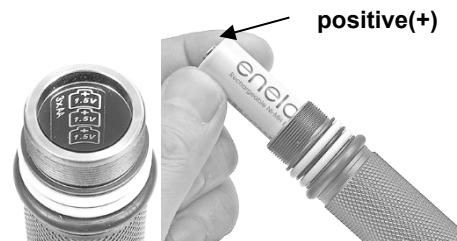
**Attach the LE600h-W Light Head**

Apply thin film of INON grease on the thread part of the 3xAA Battery Box III to prevent salt build-up or electric corrosion causing to anchoring between the "LE600h-W Light Head" and the "3xAA Battery Box Unit III". Do not put grease on electrical contacts to avoid bad connection.

Make sure the LE600h-W is OFF once again at this stage, then slowly screw the LE600h-W Light Head onto the Battery Box III until it has been stopped with holding the 3xAA Battery Box III firmly.

To keep waterproof property, make sure slowly turn the switch/LE600h-W Light Head to prevent O-ring from being damaged/twisted.

**Attach an Accessory as necessary**

Attach Red Filter LE if necessary. Refer to respective user manual for detail.

Red Filter LE is dedicated for underwater use and not usable on land.

Operation

ON/OFF the LE600h-W

To turn OFF the LE600h-W, slowly turn the Switch counterclockwise with holding the "3xAA Battery Box III" securely until it has been lightly stopped and slowly turn the Switch clockwise until it has been lightly stopped to turn ON the LE600h-W.

Make sure to turn all the way to the either end to turn ON/OFF the LE600h-W. Any position except ON/OFF may possibly cause unstable operation like unexpected ON/OFF or flicking of the LE600h-W.

To keep waterproof property, make sure slowly turn the switch/LE600h-W Light Head to prevent O-ring from being damaged/twisted.

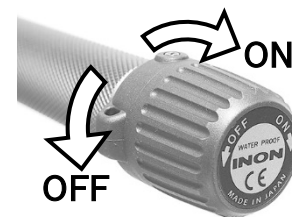
**Change/Remove Batteries**

The LE600h-W must be dry to change/remove batteries in accordance with above "Preparation" section.

If even a small amount of water contacts inside "LE600h-W Light Head" or contacts/terminals for short period of time, there will be corrosion of contact points or cause short circuit, and the LE600h-W may become inoperable.

Changing/removing batteries is not recommended if the LE600h-W is not completely dry. If you have to change/remove battery before drying the LE600h-W, follow procedure below:

- 1) **Thoroughly wash the LE600h-W in fresh water and wipe off water drops with an air blower etc.** in reference to "Maintenance" section.
- 2) **Hold the LE600h-W with facing up** so that no water droplets can enter inside the "LE600h-W Light Head" or drip on contacts/terminals.
- 3) **Slowly unscrew the "LE600h-W Light Head" with facing it up** to prevent water from getting in to take out batteries.

Maintenance

Rinse and Dry Completely

After dive soak the LE600h-W in fresh water for several hours (water temperature should be 0°C ~ +30°C/32°F ~ 86°F) **without any filter** to remove salt etc. Slowly turn the Switch to remove trapped salt etc. but DO NOT turn the "LE600h-W Light Head" underwater.

Then **wipe off water droplets by an air blower etc.** and dry the product completely in shaded and well ventilated area (it may take several days completely dry).

Remove Batteries and Check/Clean/Grease Thread Part/O-rings etc.

Make sure that the LE600h-W is completely dry, remove batteries in reverse procedure to loading batteries explained in "Preparation" section

Separate the "LE600h-W Light Head" and the "3xAA Battery Box III" in accordance with "Preparation" and check/clean/grease O-rings, O-ring grooves, O-ring contact surfaces and thread parts of the "LE600h-W Light Head"/"Battery Box III" in reference to separate paper "**Measures to Prevent Accidental Flooding**".

Storage

Make sure to remove all batteries, then store in shaded and well-ventilated area within temperature range of [0°C ~ 30°C/32°F ~ 86°F].

Avoid storing near chemicals, high ozone, large temperature and humidity fluctuations (even in the temperature range described above) and magnetic fields (TV sets etc.) to prevent the product from possible malfunction and flooding.

- Handling precautions:**
- DO NOT disassemble the “LE600h-W Light Head” to avoid malfunction/flooding.
 - Protect from impact shock and vibration, such as vibrating boat deck to avoid accidental damage not only on this product but also on batteries.
 - Prevent sands or foreign substances from entering between the 3xAA Battery Box III and the Switch to avoid malfunction/flooding etc.
 - Do not leave the product to extreme heat, such as inside of a sun-heated car or in front of a heater, or in hot direct sunlight, such as a beach or boat deck to avoid malfunction/flooding etc.
 - The LE600h-W is designed to withstand external pressure (water pressure), but not internal pressure (when ambient air pressure decreases). When traveling to or from high altitudes, including travel on an aircraft, always remove or loosen the “LE600h-W Light Head”.
 - Always hold the “3xAA Battery Box III” instead holding the “LE600h-W Light Head” to prevent accidental loosening of the “LE600h-W Light Head” leading to flooding.
 - **This product is not usable on land except function check for short period of time(※).** Even for a short period of time to check function on land, be sure to use heat-safe gloves etc. The “LE600h-W” surface and “3xAA Battery Box III” surface could have heat more than 50°C/122°F causing personal injury like burn/low temperature burn.
 - ※The function check on land can be conducted only when outer surface of the LE600h-W is below air temperature and **test time should be limited within 5 minutes.** If you need to do consecutive function check, make sure to cool down the unit until its surface gets below air temperature. Working/storage temperature of this product is 0~30°C/32~86°F.
 - Follow any other handling instructions/precautions explained in separate paper */Safety precautions/*.
 - When turn OFF this product, **always turn counterclockwise all the way to the end. Unload all batteries** when not in use including during transportation to avoid accidental malfunction/fire/personal injury resulting from unexpected activation of this product by vibration etc.

- Battery**
- As batteries have been used, battery voltage gradually decreases making the LE600h-W intensity gets dark little by little. The rated continuous operable time is the duration to get half brightness comparing to initial performance.
 - In general, battery performance will decrease as temperature lowers, voltage will recover when not in use and batteries will slowly discharge over time when not used. And, usable time can greatly vary depending on water temperature and how the batteries are used etc. **We recommend replacing with sufficiently charged batteries even before they have been fully drained or carrying spare LE600h-W to avoid battery run out in the middle of a dive especially for night dive.**
 - Some NiMH batteries have high self-discharge rates and will begin to decrease their performance (intensity/continuous operable time etc.) immediately after charging. So we recommend using those NiMH batteries within one day after charging.
 - Also their performance will decrease gradually with repeated charging and discharging, even within the possible number of charge-discharge cycles stated on the product package. When you observe less intensity/continuous operable time even with fully-charged (or refreshed) batteries, we recommend to change all batteries.
 - Together with these guidelines, be sure to read and understand *[Safety Precautions]* and any instructions that come with your batteries(rechargeable batteries/battery charger) and comply with any battery manufacturer requirements to ensure proper operation.

- Options**
- **Quick Holder Set S-LE**
Optional product to attach/remove single INON LE series LED flashlight including this product on “[YS Adapter]compatible arm” instantly (A set of **Quick Holder LE** and **Quick Base S**).
Especially for handy and compact camera system set-up with **INON Shoe Base**.
 - **Single Light Holder LE**
Optional product to attach single INON LE series LED flashlight including this product on “YS Adapter compatible arm”.
Especially for handy and compact camera system set-up with **INON Shoe Base** or **Grip Base D4**.
 - **Double Light Holder LE** (left in the image)
 - **Quad Light Holder LE** (right in the image)
Optional product for sole use underwater to attach two or four INON LE series LED flashlights including this product on compatible lighting arm.
Together with the **Z Joint**, this product is directly attached on “YS Adapter compatible arm” including **Shoe Base** etc. Combination with the **Z Adapter MV/Z Adapter II** enables to attach on INON “Arm System” with **Clamp III**.

Double Light Holder LE : Holds two INON LE series LED flashlights

Quad Light Holder LE : Holds two or four INON LE series LED flashlights

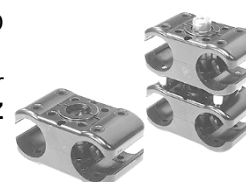



(continued)

- Strobe Light Holder LE
Optional product to attach one or two INON LE series LED flashlight on compatible lighting arm together with INON **S-2000**, **D-200** or **Z-330** etc. Together with the **Z Joint**, this product is directly attached on "YS Adapter compatible arm" including **Shoe Base** etc. Combination with the **Z Adapter MV/Z Adapter II/Z Adapter** enables to attach on INON "Arm System" with **Clamp III**.



- Z Joint
Optional product to attach **Double Light Holder LE/Quad Light Holder LE/Strobe Light Holder LE** on "YS Adapter compatible arm".



- Z Adapter MV
Optional product to attach **Double Light Holder LE/Quad Light Holder LE/Strobe Light Holder LE** on INON "Arm System" with **Clamp III**.
The plastic ball-joint provides flexible strobe positioning even without loosening the **Clamp III** to make it easy to adjust strobe/LED flashlight aiming.

- Z Adapter II
Optional product to attach **Double Light Holder LE/Quad Light Holder LE/Strobe Light Holder LE** on INON "Arm System" with **Clamp III**.
The ball-joint is made from metal to firmly fix strobe position by lightly clamp the **Clamp III** (it is necessary to loose the **Clamp III** to adjust strobe/LED flashlight aiming).

- Bar Mount
Optional product to attach INON LE series LED flashlight including this product on a bar ($\phi 22.2\text{mm} \sim \phi 31.8\text{mm}$) via **Quick Holder Set S-LE**, **Single Light Holder LE** or **Strobe Light Holder LE + Z Joint**.

- Spare O-ring Set (LE)
Set of two yellow oil-bearing O-rings.
Usable for Light Head and Switch. Refer to "**Measures to Prevent Accidental Flooding**" for detail.

- INON Grease
③ in the product image.
- Red Filter LE
④ in the product image.
- Color Filter LE Set (underwater use only)
Optional filter package includes below five different filters* to change color tone to suits to your camera system, shooting situation and personal preference.
Compatible filters with this product are **Pink Filter LE** and **Orange Filter LE**
*W50° Red Filter LE, W50° Pink Filter LE, W50° Orange Filter LE, Pink Filter LE and Orange Filter LE

- LE330h Light Head
Optional Light Head for INON amphibious **LE330h** which produces 330lm/6500K with 30 degree coverage supporting versatile utility and longer operable time. This Light Head is interchangeable with the original **LE600h-W Light Head** for other application.
- LE600h-S Light Head
Optional Light Head for INON **LE600h-S** which produces powerful 600lm/6500K with 30 degree coverage depending on usage. This Light Head is interchangeable with the original **LE600h-W Light Head** for other application.

Terminals/Contacts: Maintenance

With the increased capacity, improved performance, and longer lifespan of different types of rechargeable batteries, it is possible for the performance of the LE600h-W to become unstable, e.g., the battery may become unable to be recharged due to bad contacts, caused by dirt or oxidation of the terminal surface of the rechargeable battery itself in addition to "LE600h-W Light Head" terminal/contact/"3xAA Battery Box III" terminal/contact. For rechargeable battery terminals, it is difficult to distinguish through visual inspection of the terminal surface. As some rechargeable batteries can cause the above problems immediately after purchase because the terminal surface has already been oxidized, it is recommended to inspect and perform maintenance periodically on the rechargeable battery terminals and LE600h-W terminals/contacts, by following the procedures described below.

● **Battery Terminals/"LE600h-W Light Head" Terminal**

Conduct following maintenance within limitations/precautions described in battery instructions etc. if maintenance is necessary considering terminal conditions/performance of this product.

- 1) Wipe each terminal surface with a dry soft cloth/clean cotton swab (or similar) to remove any oil or similar residue.
- 2) If above step does not fully clean the terminal, dap a small amount of silver polish on a cotton swab (or similar) and wipe terminal surface until fully clean. Then clean off any silver polish residue with a clean swab.



● **"LE600h-W Light Head" Contacts/"3xAA Battery Box III" Contacts**

Clean up surface of contacts with clean cotton swab to wipe off any dirt/residual oil considering contacts' conditions/performance of this product.

"3xAA Battery Box III" contact has gold coating so maintenance should not be necessary under normal circumstances but conduct it if you observe water droplet etc.

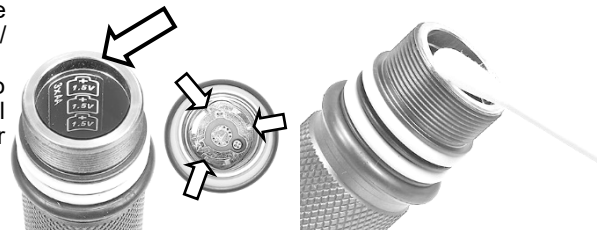

● **"Switch" Contact (Not mandatory)**

This maintenance may be necessary only for high frequent users when significant blinking is observed during switch operation. In this case you can conduct following maintenance if you are confident to disassemble/re-assemble properly or contact your purchasing dealer for servicing.

INON INC. can not take any responsibility for any damage resulting from this maintenance, so please DO NOT conduct this maintenance unless you are fully confident on this maintenance.

- 1) First remove two screws on the "Switch" then slowly turn the "Switch" counterclockwise to take it off.
- 2) Follow same procedure of above maintenance method on the "LE600h-W Light Head" contacts to conduct maintenance for contacts of "3xAA Battery Box III"/"Switch".
It is not necessary to clean the coil spring battery terminal on the "Switch".
- 3) Check and conduct maintenance on O-rings if it is necessary then re-assemble the "Switch" taking reverse procedure of above 1). Put little amount of INON grease in two screw holes on a "Stopper" then align two holes on the Switch and two screw holes on the stopper on the "3 x AA Battery Box III" then fix the Switch with two screws. Holding the Stopper with bamboo stick or similar makes it easier to align screw holes during you screw on the Switch again.

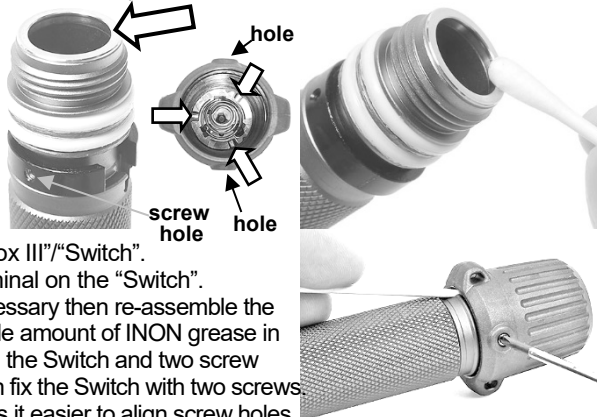

INON Waterproof LED Light LE600h-W Specifications (*1)

LED	High-intensity Power LED (Cree XM-L2™T4™)
Luminous flux(*2)(*3)	600 lumen
Coverage	75° [without a filter and with packaged Red Filter LE]
Color Temp. (*3)	approx. 6,500K
Operable duration (*4)(*5)	approx. 60 minutes [“eneloop” battery] approx. 80 minutes [“eneloop pro” battery]
EMC standards	EN 55015:2013, EN 61547:2009, CRF 47 FCC Part 15 Subpart A and B, ICES-003:2020(Issue 7), AS CISPR 15:2017
LED life time	approx. 10,000 hours

Compatible Battery	AA “eneloop” / “eneloop pro” battery x 3 (*6)
	AA NiMH [good quality] x 3 (*7)(*8)
	AA Alkaline battery [good quality] x 3 (*8)
	AA Lithium battery [good quality] (1.5V) x 3 (*8)
Depth rating	120m / 394'(*9)
Size (*10)	Max. diameter 33.7mm/1.3" x 193.6mm/7.6"
Weight (*10)	Air: 217.5g/7.7oz, Underwater: approx. 131g/4.6oz
Working/Storage Temperature	0°C ~ 30°C/32°F ~ 86°F
Material/ Finishing	Corrosion resistant aluminum alloy/rigid almite, PBT, Optical glass etc.
Standard accessory	Red Filter LE, Hand Strap, INON Grease

*1) Subject to change without prior notice

*2) Nominal value calculated from LED manufacture specification sheet.

*3) Due to individual variability of LED, drive circuit or battery etc., luminous flux, color temperature or intensity may vary within rated specification.

*4) Average time to get half brightness when continuously turn ON the product with below listed batteries underwater (approx. 25°C/77°F).

• “eneloop” battery : Panasonic “eneloop”, BK-3MCC, 1.2V, Min.1,900mAh

• “eneloop pro” battery : Panasonic “eneloop pro”, BK-3HCD, 1.2V, Min.2,500mAh

*5) Actual measured data by INON. The value may vary depending on product individual variability, battery manufacture/model, test condition.

*6) “New generation” NiMH batteries carrying less self-discharging and heat generating characteristic comparing to “conventional” or “high-capacity” NiMH including listed batteries in right confirmed compatible by INON INC. as same as recommended [Panasonic “eneloop”/“eneloop pro” battery (BK-3MCC, BK-3HCC / BK-3HCD)] .

• Panasonic Corporation

• Panasonic Corporation

• SANYO Electric Co.,Ltd

• SANYO Electric Co.,Ltd

• Sony Corp.

• Panasonic Corporation

• Maha Energy Corporation

• GP Batteries International Ltd

• ANSMANN AG

• ElectrochemAutomation Inc.

Model name: eneloop [recommended] /Model code: BK-3MCC

Model name: eneloop pro [recommended] /Model code: BK-3HCC / BK-3HCD

Model name: eneloop [recommended] /Model code: HR-3UTG/HR-3UTG/HR-3UTGB

Model name: eneloop pro [recommended] /Model code: HR-3UWX

Model name: Cycle Energy Blue/Model cod : NH-AA-2BKA, NH-AA-4BKA

Model name: Rechargeable Ni-MH (AA)/Model code : HHR-3MPS

Model name: IMEDION/Model code : MHRAA4

Model name: ReCyko+ /Model code : 210AAHCBE

Model name: maxE/Model code : 5030991, 5030992, 5035052

Model name: NEXcell energyON/Model code : n/a (AA 2000mAh)

*7) Some “conventional” or “high-capacity” NiMH rechargeable batteries have significant self-discharge and heat-generating characteristic resulting difficulty to keep their performance during usage. We recommend using recommended batteries.

*8) Run time very much depends on battery characteristic, quality. Make sure to use quality battery supporting continuous discharge of large current not to have battery leakage as well.

*9) Without operating the “Switch”. INON has confirmed depth rating 84m/276' including switch operation.

*10) Including 3 x AA “eneloop” batteries

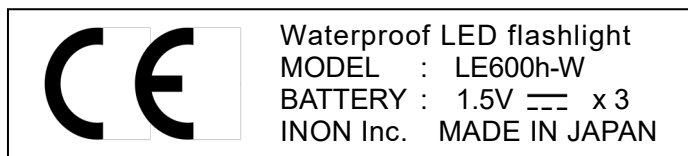

FCC Notice

This device complies with part 15 of the FCC Rules. Operation is subject to the following two conditions:

- (1) This device may not cause harmful interference, and
- (2) This device must accept any interference received, including interference that may cause undesired operation.

Information to user

The user that changes or modifications not expressly approved by the party responsible for compliance could void the user's authority to operate the equipment.

NOTE: This equipment has been tested and found to comply with the limits for a Class B digital device, pursuant to part 15 of the FCC Rules. These limits are designed to provide reasonable protection against harmful interference in a residential installation. This equipment generates, uses and can radiate radio frequency energy and, if not installed and used in accordance with the instructions, may cause harmful interference to radio communications. However, there is no guarantee that interference will not occur in a particular installation.

If this equipment does cause harmful interference to radio or television reception, which can be determined by turning the equipment off and on, the user is encouraged to try to correct the interference by one or more of the following measures:

- Reorient or relocate the receiving antenna.
- Increase the separation between the equipment and receiver.
- Connect the equipment into an outlet on a circuit different from that to which the receiver is connected.
- Consult the dealer or an experienced radio/TV technician for help.

CAN ICES-003(B) / NMB-003(B)

Notice

This Class B digital apparatus complies with Canadian ICES-003.

Avis

Cet appareil numérique de la classe B est conforme à la norme NMB-003 du Canada.

INON INC. 2-18-9 Dai, Kamakura, Kanagawa, 247-0061
E-mail support@inon.co.jp Fax. +81(0)467-48-2178
URL <http://www.inon.jp/>

As of December 2020

Measures to Prevent Accidental Flooding

Thank you for purchasing INON product.

The INON LED light LE series is waterproof by a rubber O-ring enabling underwater use.

This O-ring must be inspected each time before using LED light to ensure waterproof integrity. Equally important are O-ring contact surfaces. Always check the contact surfaces for contaminants or scratches.

O-ring Inspection Locations

User serviceable O-rings/O-ring contact surfaces are O-rings on a "Battery Box" (Light Head side) and O-ring contact surfaces on a "Light Head" indicated in image right. Be sure to check condition of each O-ring including dust/foreign substances and condition of O-ring in accordance with next section.

Factory overhaul of an O-ring for switch part may be necessary depending on frequency of use/condition of product like when you feel tight to turn the switch or foreign substances have been trapped between the "Switch" and the "Battery Box". Refer to 「Maintenance of "Switch" O-ring」 section.

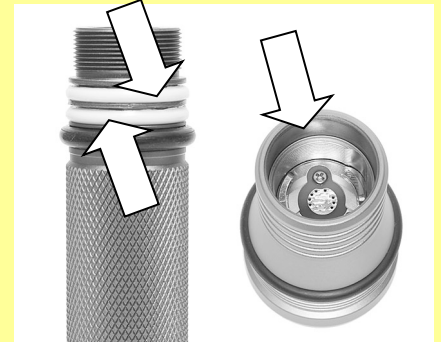

O-ring Inspection Method

These are the essential factors ensuring waterproof property:

- The O-ring itself
- O-ring contact surfaces
- O-ring grooves
- If O-ring is properly seated in groove
- Grease

If any of the following are evident, there is a high chance that the strobe will flood if placed in water. Be very careful about checking these points when you exercise following inspection.

If hair, sand, lint or other debris is attached to the O-ring

Remove O-ring and wipe-off the debris in reference to next section 「Installing/Removing O-ring」.

If the O-ring is cut or cracked

The O-ring must be replaced with a new O-ring. See 「Installing/Removing O-ring」 for replacement.

If the O-ring is twisted

The O-ring must be removed and reinstalled uniformly with no twists or other irregularities. See next section 「Installing/Removing O-ring」 for reinstallation.

If there is hair, sand, lint or other debris on the O-ring contact surfaces

Wipe off any debris.

If there is a scratch, blemish on the O-ring contact surfaces

The product must be inspected by an authorized technician, and repaired if possible. Contact your dealer for advice.

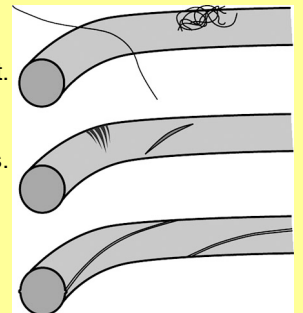

O-ring Maintenance Method

INON yellow O-rings are compounded with a special type of oil which naturally migrates to the O-ring surface, but which is not compatible with all grease types while benefit you with less frequent maintenance. **Do not use any other grease or other oil/fat containing material, which may cause the O-rings to swell or deform, causing poor seal and water leakage.** Use 「INON Grease」 only. Use of non-INON grease will void warranty.

"Battery Box" O-ring (Light Head side) / "Light Head" O-ring Contact Surface

First, clean O-ring contact surface of the "Light Head" with a cotton swab (or similar) to wipe off old grease and residue then **periodically apply thin film of supplied INON grease** both on "Battery Box" O-ring (Light Head side)/"Light Head" O-ring contact surface ensuring waterproof integrity with oil film to prevent damage/twist caused by friction during removing/installing the "Light Head". Also put a little amount of grease between two yellow O-rings.

Never put grease on any terminals/contacts of "batteries", "Light Head", "Battery Box" and "Light Head".

Always slowly turn the "Light Head" whenever remove/attach it to prevent excessive load on O-rings.

If O-rings are heavily stained or debris are attached, conduct necessary maintenance in accordance with next section 「Installing/Removing O-ring」.

"Battery Box" O-ring (switch side) / "Switch" O-ring Contact Surface

Maintenance is not necessary under normal condition and frequency of usage. However if you observe problem to turn the "Switch" due to heavy usage/salt build-up or any foreign substances have been trapped between the "Switch" and the "Battery Box", "Switch" O-ring maintenance is necessary in accordance with 「"Switch" O-ring Maintenance」 section.

Installing and Removing O-ring

Your LE series LED light has been pressure tested, inspected and passed before shipping. It is now your responsibility to prevent any water leakage by properly maintaining the O-ring. It may be necessary to remove the O-ring, for cleaning or replacement. Accordingly, please follow the next steps carefully.

To remove each O-ring, lightly squeeze from the sides so it bulges out from one side, grasp and pull off, as in figure below. Clean any residual grease or debris from the O-ring groove and contact surface, and check the condition of both surfaces. Wipe off O-ring to see if it is still useable or not. If you need to replace O-ring, optional O-ring set is available to purchase. Refer to LE series user manual for detail of options and prepare optional 「Spare O-ring Set (LE)」.

Using your fingertips, apply a thin uniform film of INON grease on the O-ring. Gently install the O-ring in the O-ring groove, not stretching it too much, and making sure it is seated uniformly and not twisted nor damaged by the thread part of the "Battery Box". If you see any twists, take off and re-install. Then put a little amount of INON grease between two O-rings and wipe off any grease on the "Battery Box" contact

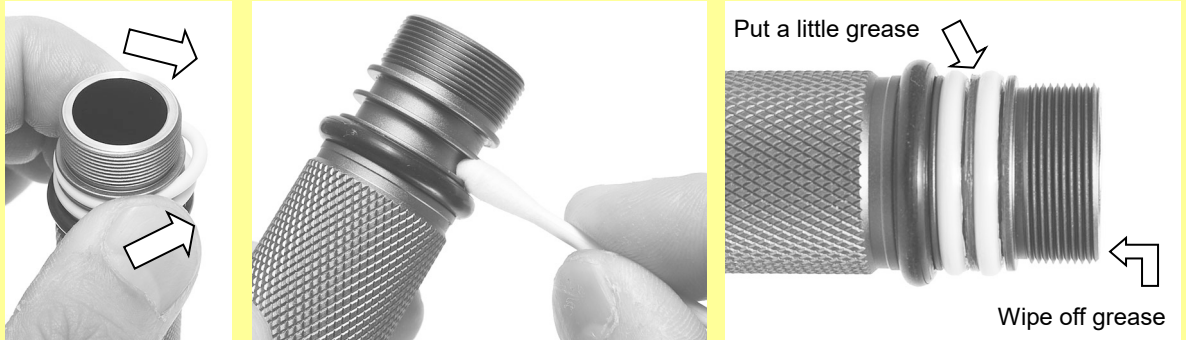

“Switch” O-ring Maintenance

Maintenance is not necessary under normal condition and frequency of usage. However if you observe problem to turn the "Switch" due to heavy usage/salt build-up or any foreign substances have been trapped between the "Switch" and the "Battery Box", "Switch" O-ring maintenance is necessary. Please contact your purchasing dealer for factory overhaul.

If you are confident to disassemble/re-assemble the "Switch" part properly, you can conduct "Switch" O-ring maintenance. **INON INC. can not take any responsibility for any damage resulting from this maintenance, so please DO NOT conduct this maintenance unless you are fully confident on this maintenance.**

First remove two screws on the "Switch" then slowly turn the "Switch" counterclockwise to take it off. Follow same procedure of above maintenance method of the "Battery Box" O-rings (Light Head side) to conduct maintenance of "Battery Box" O-ring, O-ring groove and O-ring contact surface on the "Switch".

Refer to separate 「user manual」 to check and conduct maintenance on terminals/contacts if it is necessary then re-assemble the "Switch" taking reverse procedure of above disassemble procedure. Put little amount of INON grease in two screw holes on a "Stopper" then align two 『holes』 on the "Switch" and two 『screw holes』 on the 「stopper」 on the "Battery Box" then fix the "Switch" with two screws. Holding the 「Stopper」 with bamboo stick or similar makes it easier to align screw holes during you screw on the "Switch" again.

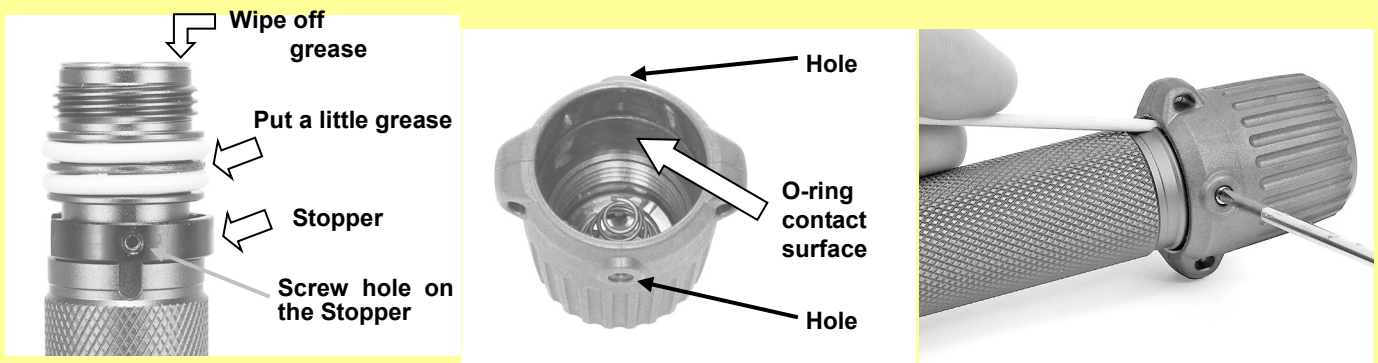

INON INC.

2-18-9 Dai, Kamakura, Kanagawa 247-0061 JAPAN
E-mail support@inon.co.jp / URL <http://www.inon.co.jp/>

Fax. +81(0) 467-48-2178
As of December 2009

INON

INON Red Filter LE INON W40° Filter LE INON W50° Filter LE

Thank you for purchasing INON product.

INON Filter LE series provides additional features for compatible INON LED flashlight, INON “Diffuser 2” series and INON “Color Temperature Conversion Filter” series.

- Function** :
- **Red Filter LE ①**
 - 1) Suppress influence of light on shy subjects.
 - 2) Prevents Focus Light influence when Z-240/D-2000 operates S-TTL auto exposure for super macro subject (shooting distance is 5cm/2” or less and distance between a strobe and subject is 10cm/4” or less) to support precise and accurate S-TTL auto exposure control. Refer to user manual of Z-240/D-2000 strobe for detail of S-TTL auto.

The Red Filter LE is underwater use ONLY. Not usable on land.

- **W40° Filter LE ②** *Not compatible with the LE330h/LE350/LE350 Type2/LE550-S/LE600h-S/
LE700-S/LE700-S Type2/LE700-W/LE700-W Type2
 - 3) Effectively diffuse LED flashlight/strobe built-in Focus Light to provide natural and seamless wide LED light (approx. 40°).
- **W50° Filter LE ③** *Not compatible with the LE600h-W/LE700-W/LE700-W Type2
 - 4) Effectively diffuse LED flashlight/strobe built-in Focus Light to provide natural and seamless wide LED light (approx. 50° with LE250/LE240/strobe built-in Focus Light, 65° with LE550-S, and 60° with LE350/LE350 Type2/LE700-S/LE700-S Type2) which is ideal as close range fill-in light for photography.

- Compatible product:**
- LE250 (*1)
 - LE240 (*1)
 - LE330h (*4)
 - LE350/LE350 Type2 (*4)
 - LE550-S (*2)
 - LE600h-S (*4)
 - LE600h-W (*5)
 - LE700-S/LE700-S Type2 (*4)
 - LE700-W/LE700-W Type2 (*5)
 - Color Temperature Conversion Filter(4900K) (*1)
 - Color Temperature Conversion Filter(4600K) (*1)
 - -0.5 White Diffuser 2 (External Auto) (*1)
 - -0.5 Blue Diffuser 2 (External Auto) (*1)
 - -1.5 White Diffuser 2 (External Auto) (*1)
 - -1.5 Blue Diffuser 2 (External Auto) (*1)
 - -0.5 White Diffuser 2 (TTL/Manual) (*1)
 - -0.5 Blue Diffuser 2 (TTL/Manual) (*1)
 - -0.5 (4900K) Diffuser 2 (TTL/Manual) (*1)
 - -0.5 (4600K) Diffuser 2 (TTL/Manual) (*1)
 - -1.5 White Diffuser 2 (TTL/Manual) (*1)
 - -1.5 Blue Diffuser 2 (TTL/Manual) (*1)
 - -0.5 White Diffuser 2 bundled with Z-240 strobe. (*3)



- *1) Red Filter LE/W40° Filter LE are packaged.
- *2) Red Filter LE is packaged. Not compatible with W40° Filter LE.
- *3) Red Filter LE/W40° Filter LE are packaged with the Z-240 from July 2009 production.
- *4) Red Filter LE/W50° Filter LE are packaged. Not compatible with W40° Filter LE.
- *5) Red Filter LE is packaged. Not compatible with W40° Filter LE/W50° Filter LE.

- How to Attach** :
- Screw a Filter straight in the threads of a “Light Head” of compatible LED Light or Focus Light Window on “Diffuser 2”/“Color Temperature Conversion Filter”.
Make sure to screw in straight to prevent accidental damage on thread part of a Filter, “Diffuser 2” or “Color Temperature Conversion Filter”.



INON INC.

2-18-9 Dai, Kamakura, Kanagawa 247-0061 JAPAN
E-mail / Fax. support@inon.co.jp / +81(0)467-48-2178
URL / http://www.inon.jp/

As of November 2020